

WIRELESS WITHOUT BATTERIES

Energy-Harvesting Microcontrollers for Radio Communications

by Prof. Gregory D. Durgin

durgin@gatech.edu

www.propagation.gatech.edu

Tutorial for Wireless @ Virginia Tech Symposium

5 June 2010



GRID



Why Use Microwave Backscatter?

- **Power** – application prohibits batteries
- **Cost** – communication nodes must be low \$
- **Locating** – unique ranging ability of backscatter
- **Link** – unique attributes of microwave links
- **Protocol** – flexibility for unique requirements
- **IP** – few application precedents in patent lit.



Monitor Current on High Voltage

Wind farm with capacitor bank



Fire danger!



Powerline Sensor Requirements

- Absolutely no batteries
- Extremely low power
- Near-zero latency
- Bulletproof link

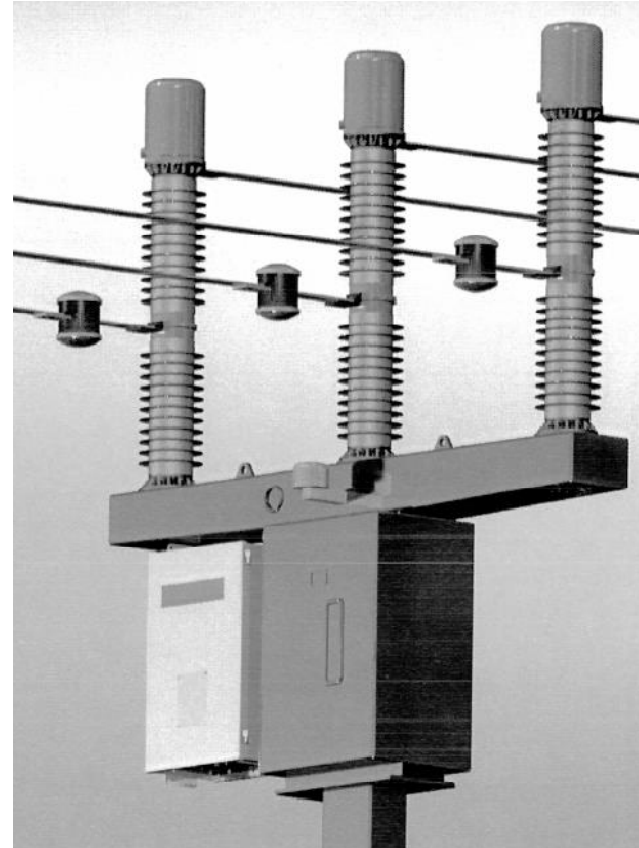

High Voltage Setup

We want to measure:

- Corona noise
- Corona modulation
- Flashover transient
- Continuous arcing

Test Setup

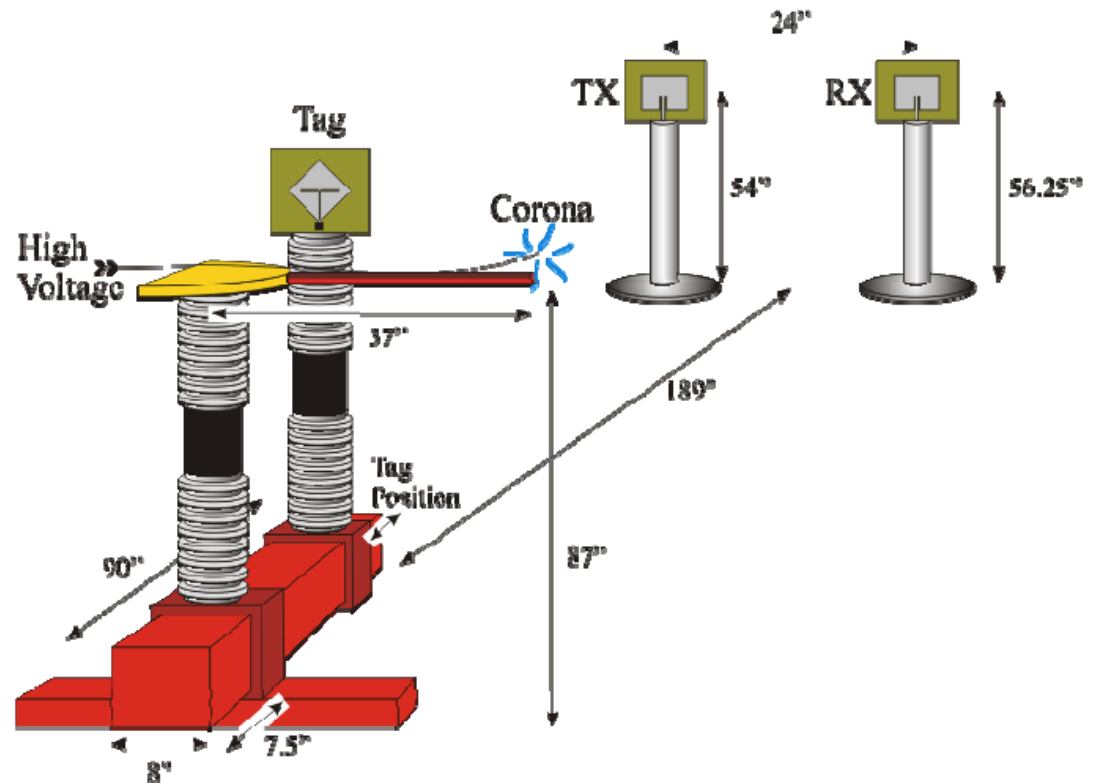

Durgin, et. al. *5.8 GHz Backscatter Sensor Measurement Across High Voltage Insulation Gaps*, PG-TR-092004-CRV, 21 April 2009. http://www.propagation.gatech.edu/Archive/PG_TR_090420_CSV/PG_TR_090420_CSV.pdf



Corona Noise

- Low-frequency effect
- Microwaves are virtually impervious to corona noise
- Measurements confirm perfect operation

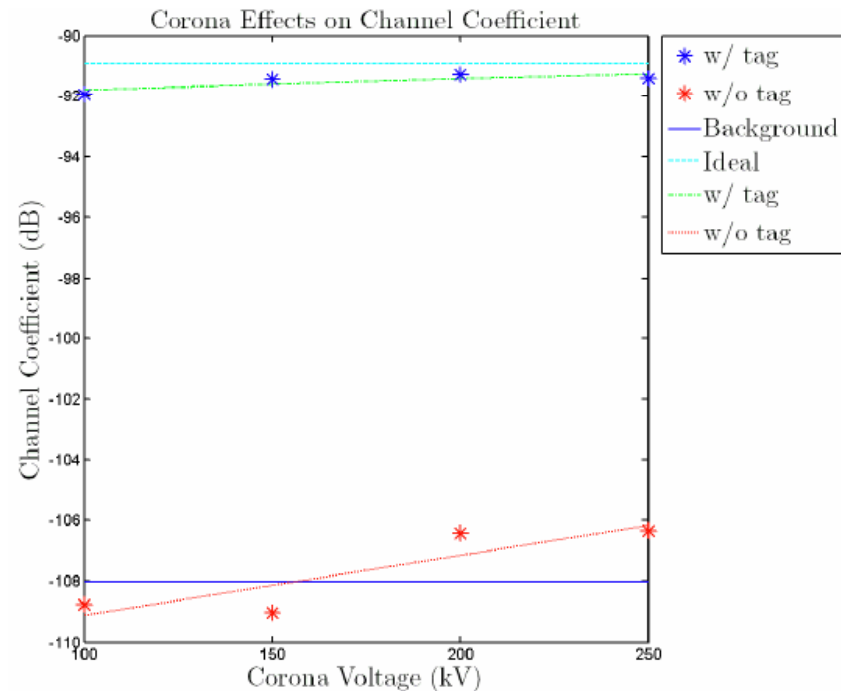

Durgin, et. al. *5.8 GHz Backscatter Sensor Measurement Across High Voltage Insulation Gaps*, PG-TR-092004-CRV, 21 April 2009. http://www.propagation.gatech.edu//Archive/PG_TR_090420_CSV/PG_TR_090420_CSV.pdf



Corona Shielding

- Direction connection to corona wire
- Fails past 100 kV
- Electronics still working
- Invisible Faraday cage

Cutoff frequency:

$$f_c = \sqrt{80.5 N_{Max}}$$

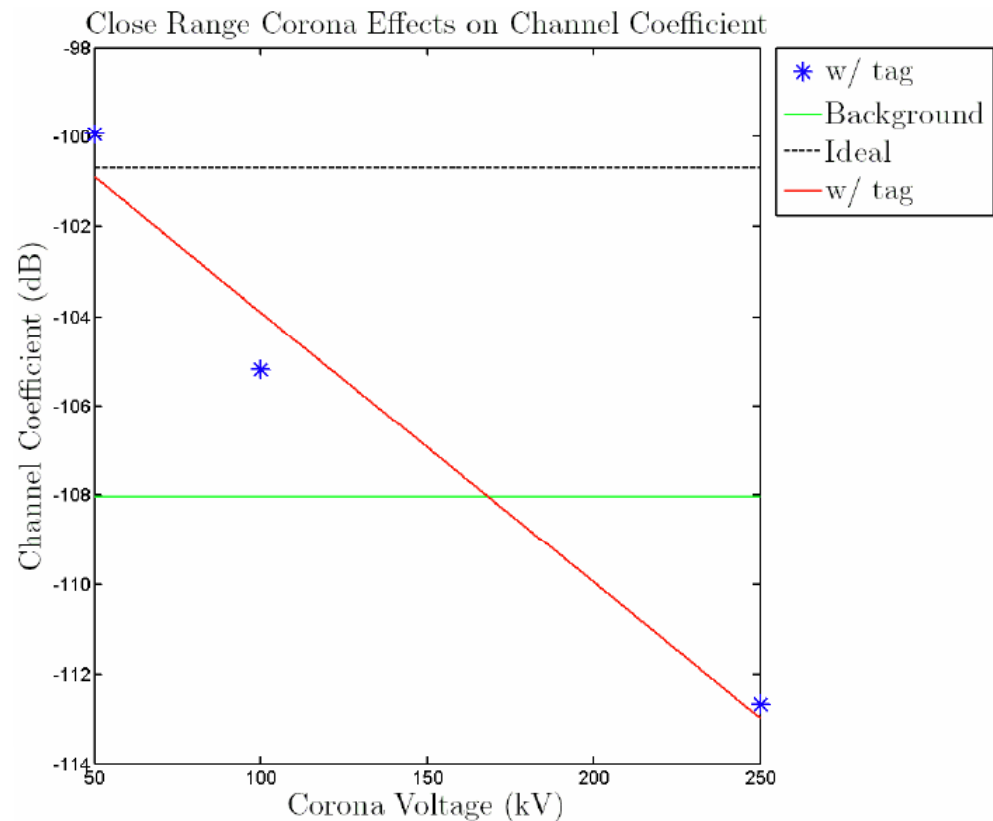

Transients and Arcing

- Equipment Failures
- Lightning and Arcing

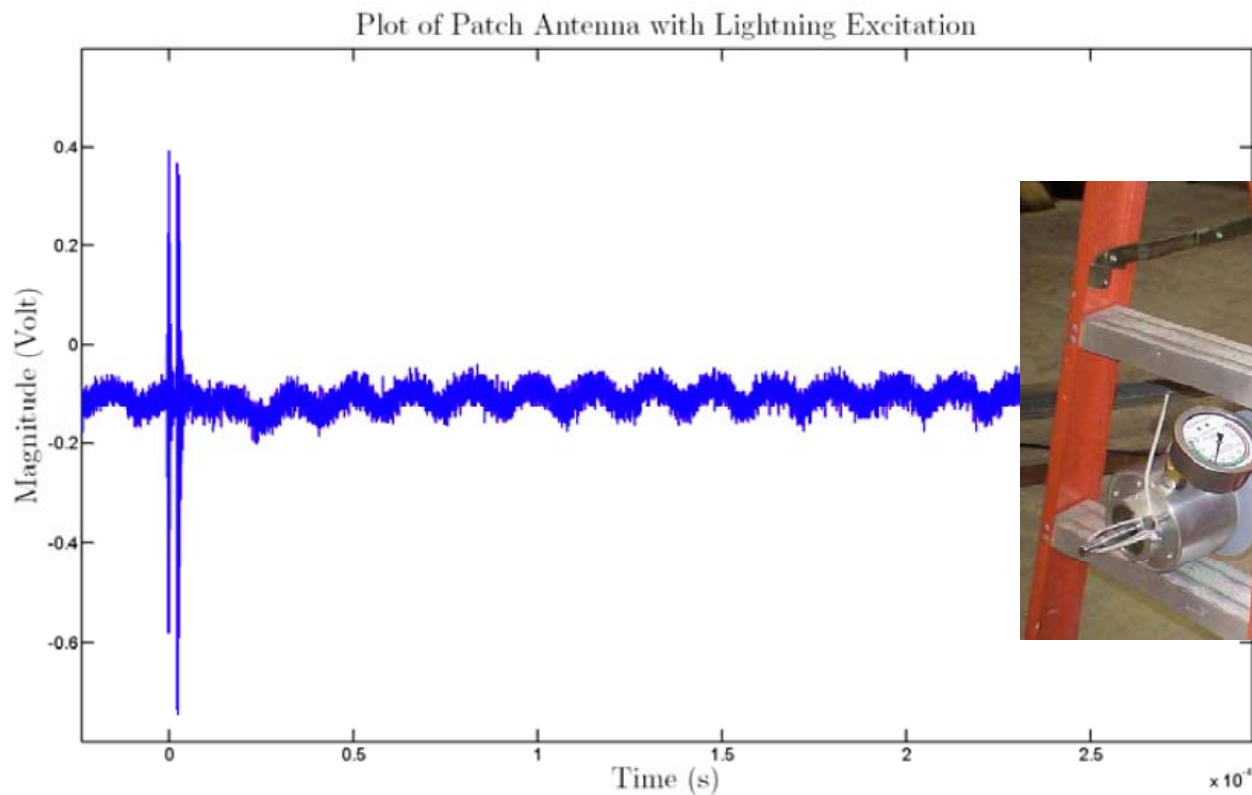

System Configuration

Communication Specs

- max 3m TR separation
- 1000 samples/sec
- 3-6 channels of sensors
- 63-chip spread spectrum
- FCC-compliant freq hopping
- $< 5\text{mW}$ sensor draw
- two 12-bit words per sample
- $\text{BER} < 1\text{e-}6$

System Picture



5.8 GHz Software Radio Platform

Full 5.8 GHz Backscatter Transceiver System

5.8 GHz Backscatter Down-converter Box

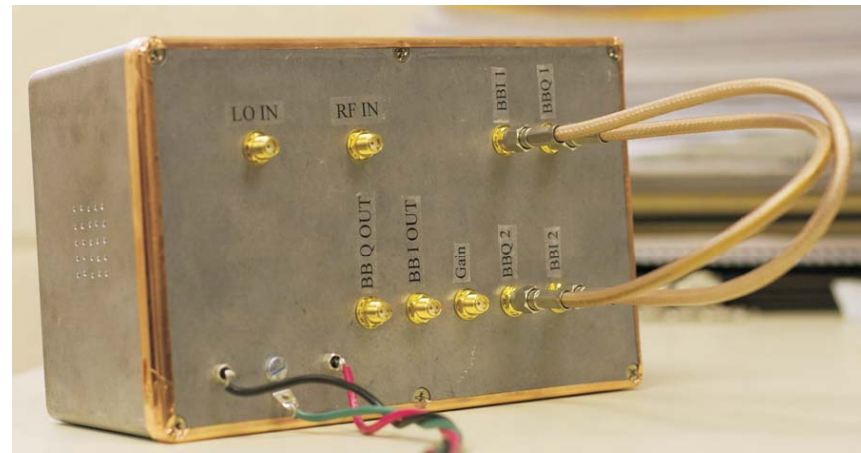
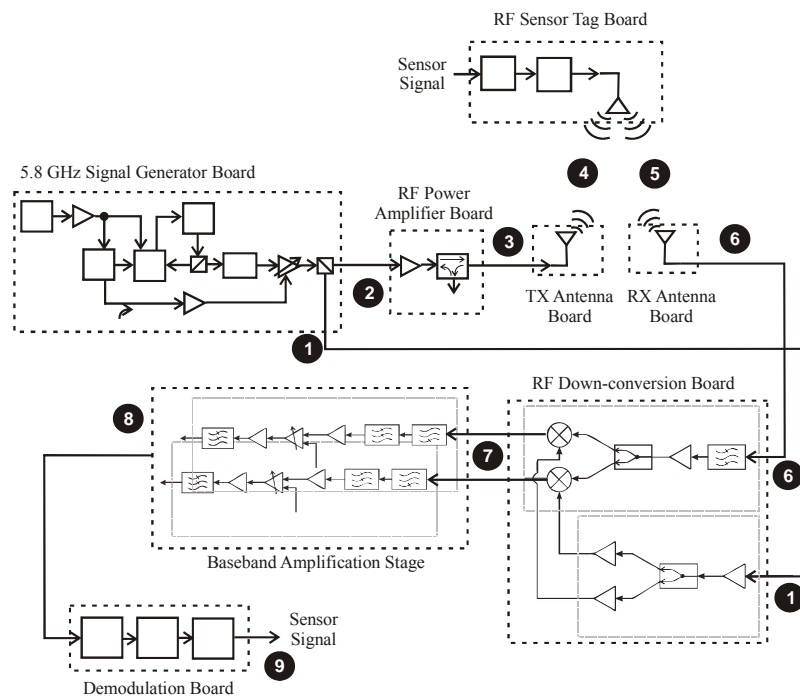

HARVESTING



Stepping-Up/Rectifying RF Power

- Dilemma in RF scavenging: we need...
 - Rectification (AC-to-DC)
 - Multiplication (stepped up voltage)
- Classical power circuits do not work
 - Optimized for stepping-down voltages
 - Require bulky inductors
 - Example right: boost circuit

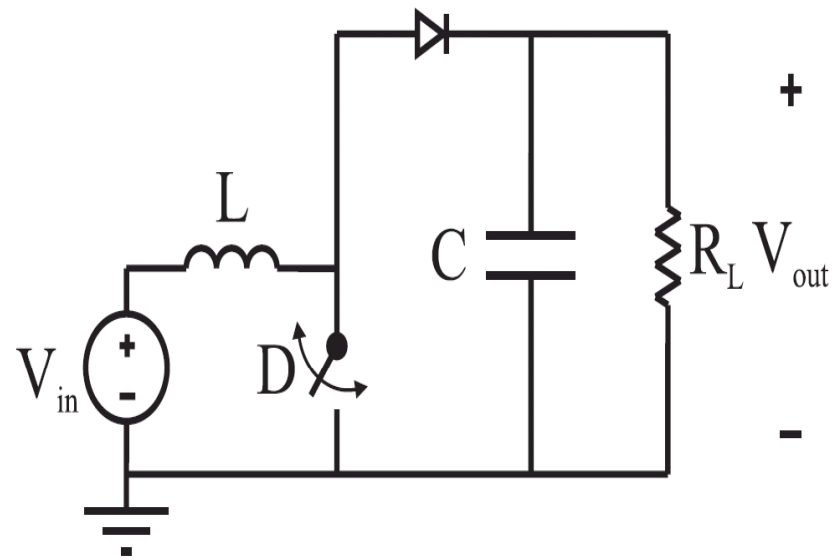

Charge Pumps

- Cockcroft-Walton multiplier (1932)
 - Only uses capacitors
 - Also requires mechanical switching
- Part of Nobel Prize-winning work on splitting atom
- Required large voltages for their particle accelerator
- Still used today

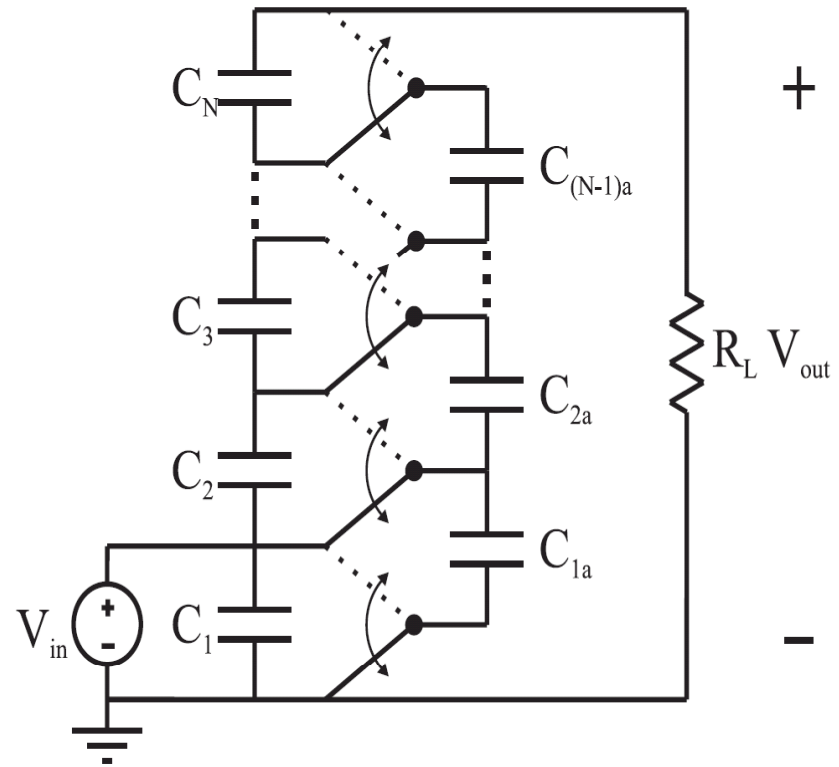

Powering Up a Passive Tag

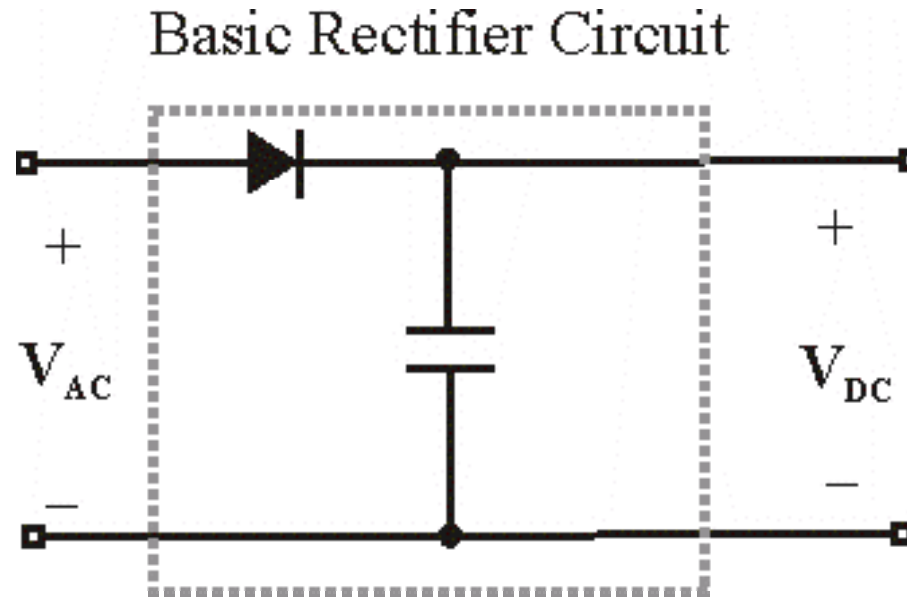

- Passive RF chip must convert incoming RF to DC voltage
- Basic rectifier shown above
 - Half-wave rectifier circuit shown above
 - Ideal Voltage Conversion: $V_{DC} = 0.5 \times (V_{AC})_{pp} - V_{TO}$
 - V_{TO} is turn-on Voltage for Diode



Powering Up a Passive Tag

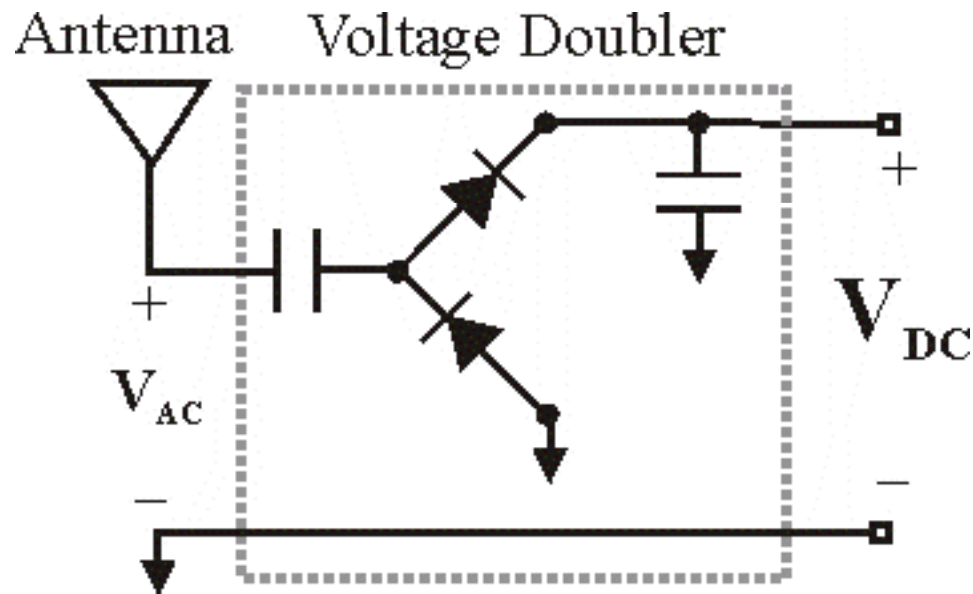

- Voltage Doubler circuit capable of producing twice the DC output with a few more capacitors and diodes
- Ideal Voltage Conversion: $V_{DC} = (V_{AC})_{pp} - 2V_{TO}$



Powering Up a Passive Tag

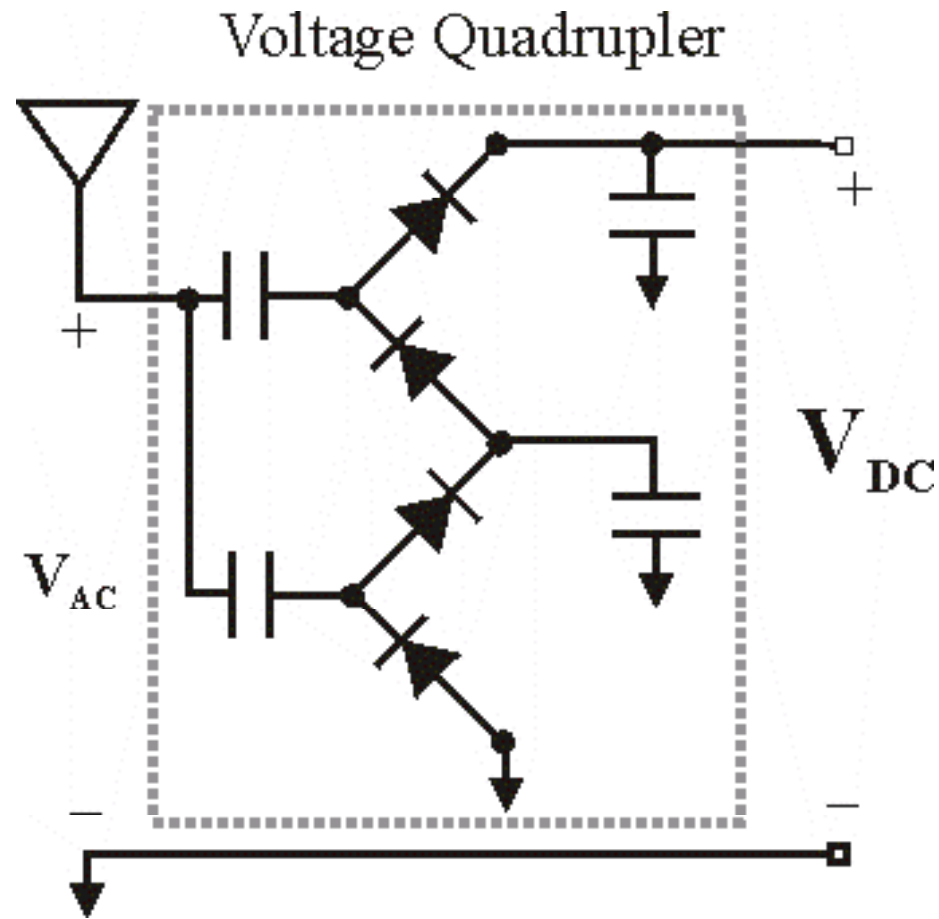

- Ideal Voltage Conversion: $V_{DC} = 2 (V_{AC})_{pp} - 4V_{TO}$



Powering Up a Passive Tag

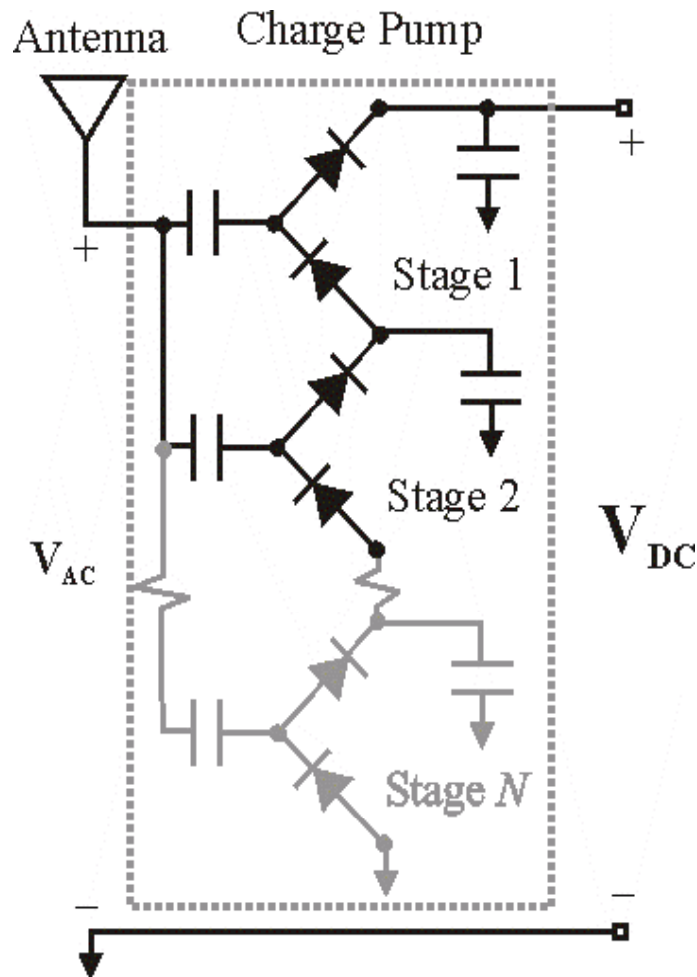

- Charge pump rectifier
 - Diodes and capacitors
 - AC voltage converted to DC
 - Voltage stepped up (current stepped down)
- Ideal Voltage Conversion:
$$V_{DC} = N(V_{AC})_{pp} - 2NV_{TO}$$
- Drawbacks
 - Higher complexity
 - Diminishing returns for added stages
 - Longer charging transient



RF Schottky Diodes

- Low Threshold Voltage as low as 0.15 V
- Very low Junction Capacitance SoE2
 - Works at RFID frequencies and higher (> 860 MHz)
- Low Reverse-Breakdown Voltage as low as 15 V
- Diodes in charge pumps:
 - Controls current flow from stage to stage
 - Threshold voltage limits output voltage, conversion efficiency.
 - Typical RFID charge pump efficiency $< 60\%$.

Dobkin, D. "The RF in RFID. Passive UHF RFID in Practice" Elsevier, 2008.



Harvesting Microwave

- Microwave Harvesters
 - Gaining efficiency
 - Requires Small Antennas
- Sample 5.8 GHz energy harvester circuit (left)

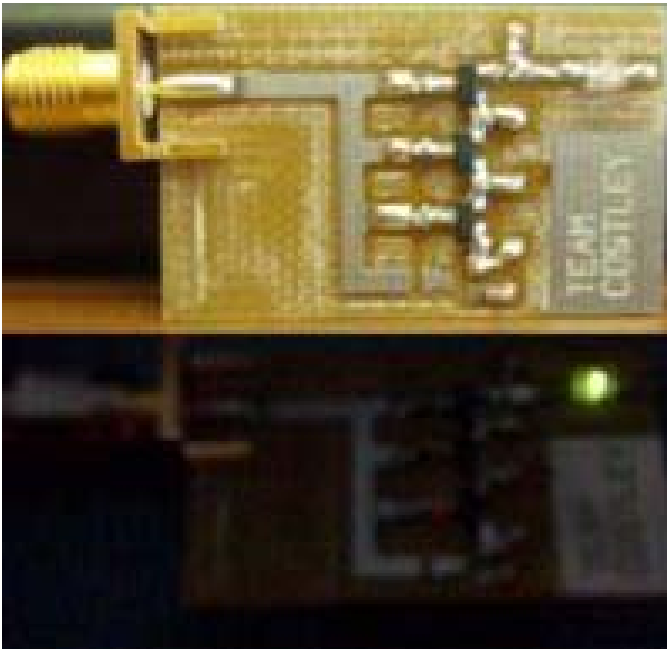

http://www.propagation.gatech.edu/ECE6361/project/Project3_09/Project3_09.htm



Rules for Antennas in Link Budgets

- Broadcast-to-Broadcast:
 - Omnidirectional TX and RX
 - lower frequency is better
- Point-to-Broadcast or Broadcast-to-Point:
 - One communication node must be omnidirectional
 - link is frequency independent
- Point-to-Point:
 - Both communication nodes can steer
 - higher frequency is better



Staggered-Pattern Charge Collector

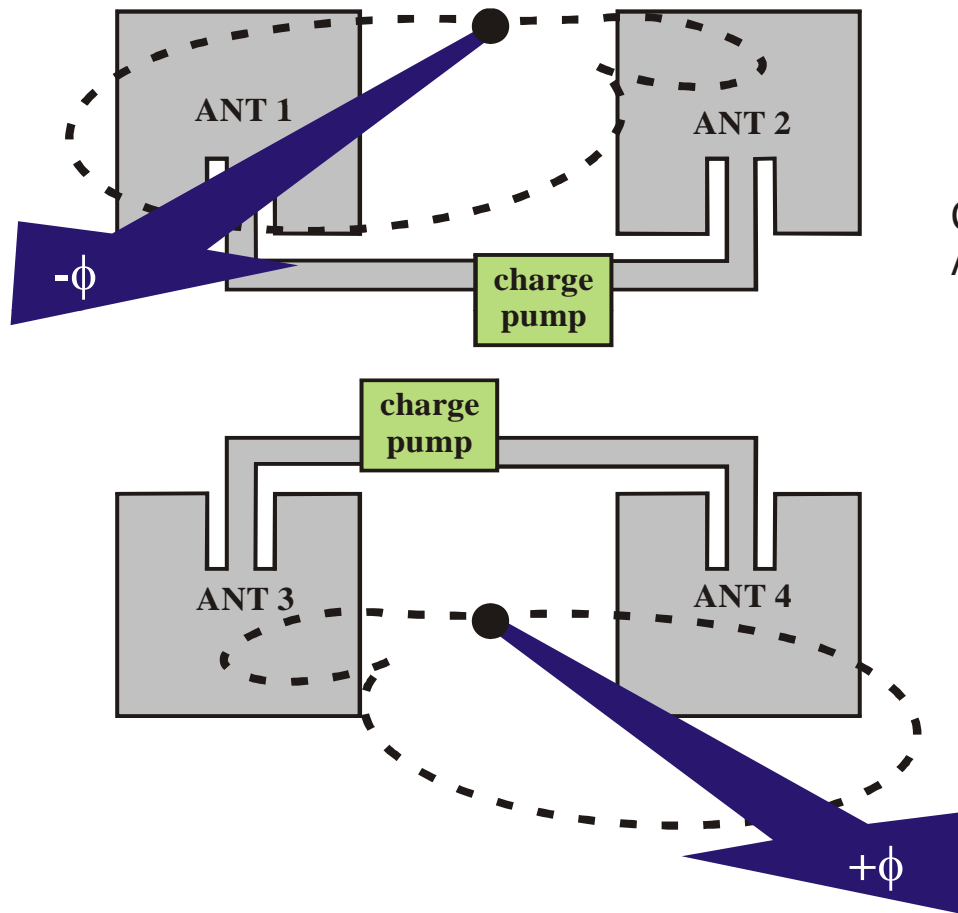

Comparison of Array Patterns

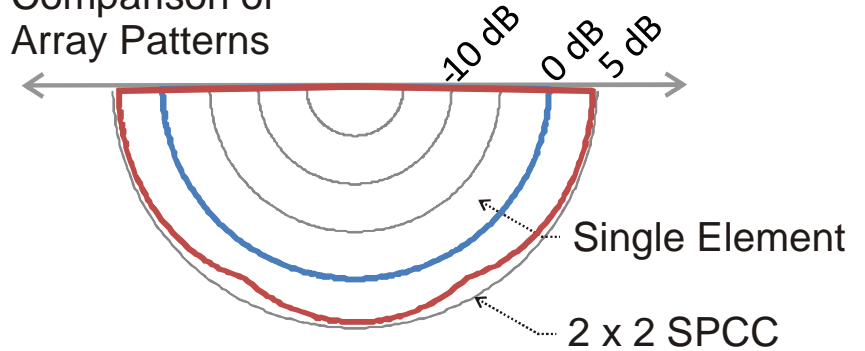

WISP



Wireless Identification & Sensing Platform (WISP)

- Open-ended, customizable ID and sensing device
- Plethora of on-board sensors:
 - Thermometer
 - Accelerometer
 - Voltmeter
 - Capacitance Meter
 - External sensor ports
 - 10-bit, 200 kSamp/s ADC

WISP Wiki. "WISP 4.1 DL". Intel Research. 2010

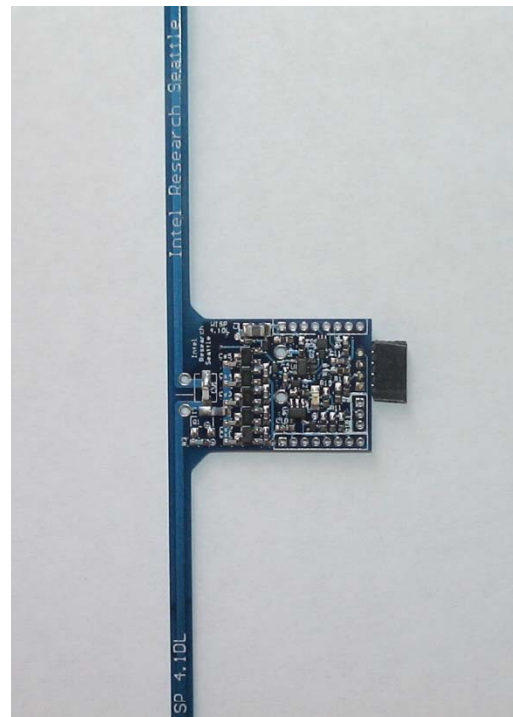

Reading a WISP

- Basic RFID communications:
 - EPC Global “gen 2” standard
 - Standard Reader with modification



Sample, A.P.; Yeager, D.J.; Powledge, P.S.; Mamishev, A.V.; Smith, J.R., "Design of an RFID-Based Battery-Free Programmable Sensing Platform," *Instrumentation and Measurement, IEEE Transactions on*, vol.57, no.11, pp.2608-2615, Nov. 2008



WISP Power Harvesting

- Ultra-low power MSP430 microcontroller
 - 600 μA @ 1.8 V during active operation
 - 0.1 μA @ 1.5 V during “sleep” mode
- 10-stage charge pump with voltage regulation
- -10 dBm power sensitivity
 - 4 m range

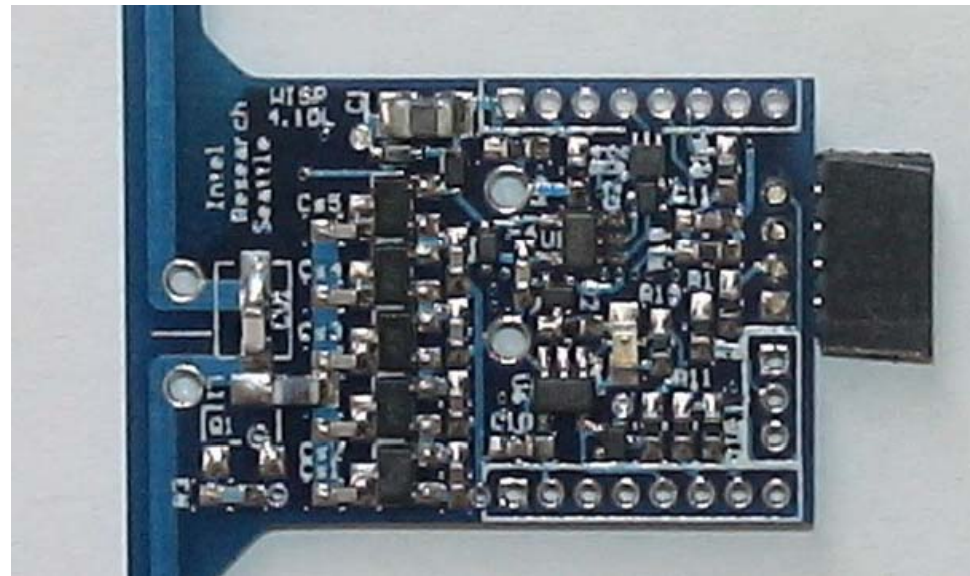

SPREADING



Spread Spectrum

- Provides resistance to interference/jamming
- Can be applied to “anticollision”
- Good for uncoordinated communication nodes
- Fits with “binary state” modulation scheme

A. Rohatgi, G. Durgin, , IEEE APS 2006, Albuquerque, NM.

C. Mutti, C. Floerkemeier, *CDMA-based RFID Systems in Dense Scenarios: Concepts and Challenges*, IEEE RFID 2008, Las Vegas, NV.

G. Durgin, A. Rohatgi, *Multi-Antenna RF Tag Measurement System Using Back-Scattered Spread Spectrum*, IEEE RFID 2008, Las Vegas, NV.

Z. Qiuling, Z. Chun, L. Zhongqi, W. Jingchao, L. Fule, W. Zhihua, *A Robust Radio Frequency Identification System Enhanced with Spread Spectrum Technique*, IEEE 2009.



Aperiodic Spread Spectrum

- Treat traditional pseudorandom sequences (i.e. Gold and Kasami sequences) aperiodically
- Analyze the aperiodic auto- and cross-correlations of a single period of traditionally periodic spread spectrum

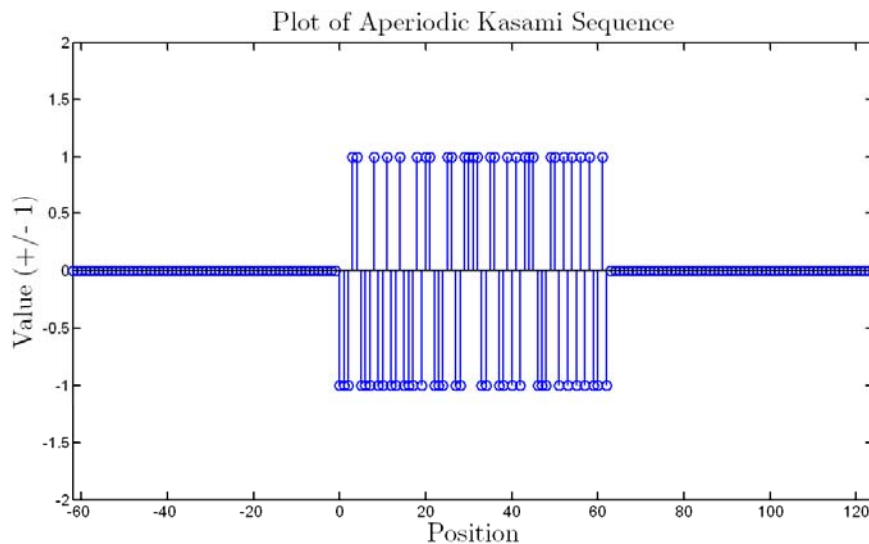

Fig. 1: Aperiodic Kasami sequence

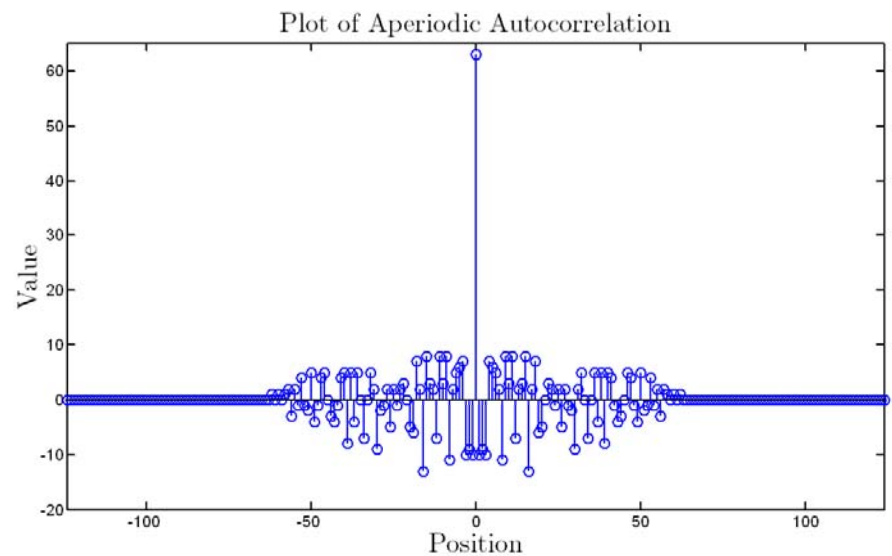

Fig. 2: Autocorrelation of the aperiodic Kasami sequence



Bit-Encoding Using Aperiodic Sequences

- Encode data symbols using different pseudorandom sequences
- Auto- and cross-correlations of each symbol (sequence) match aperiodic auto- and cross-correlations under certain conditions

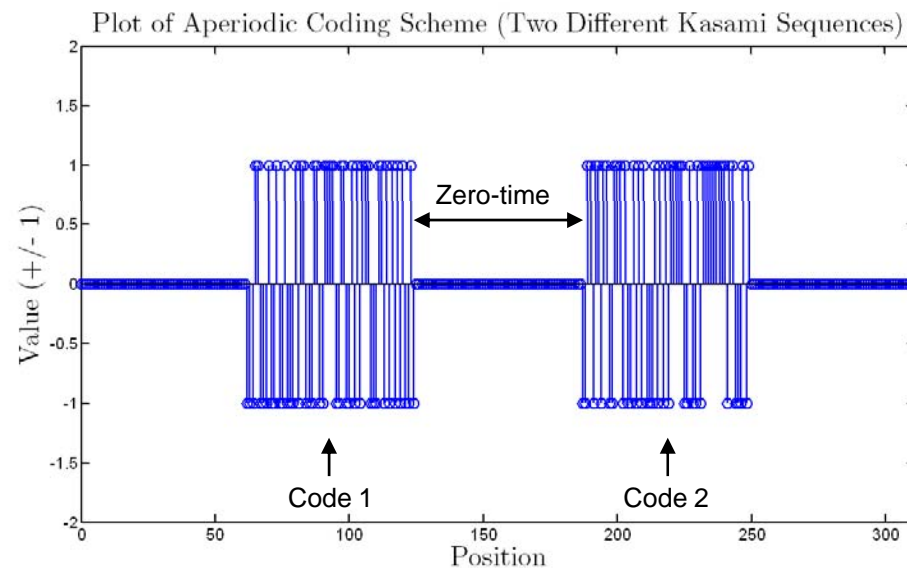

Fig. 3: Symbol encoding using multiple pseudorandom sequences



Sequence Selection

- Well-defined periodic cross-correlation bounds do not hold for aperiodic cross-correlations
- Zero-time between symbols, pseudorandom sequence selection and phase rotation of each sequence affect interference levels

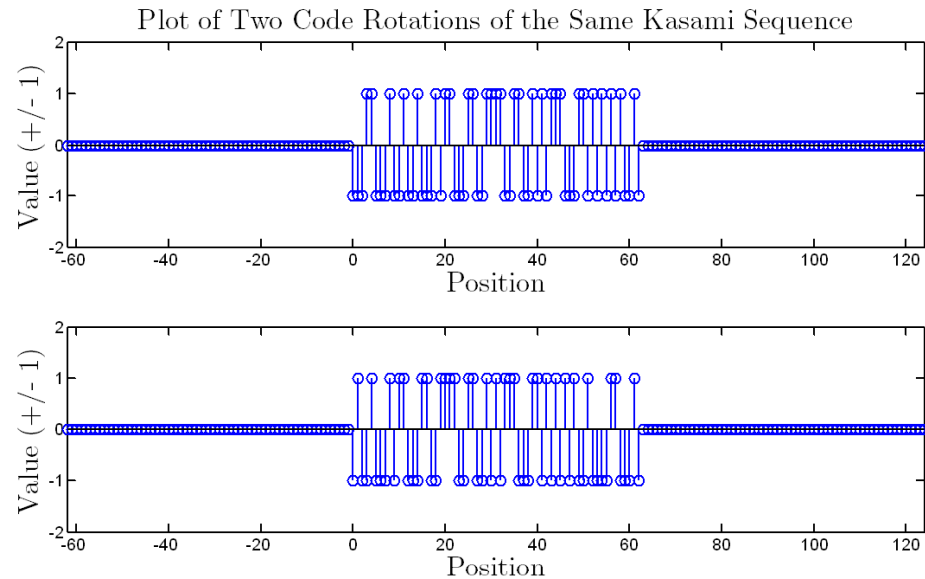

Fig. 4: Two phase rotations of a single Kasami sequence



Tradeoffs of Aperiodic Spreading

■ Benefits

- ❑ Systems capable of two-state load modulation can implement higher order modulation schemes
- ❑ Communication link is more robust against narrowband interference
- ❑ Zero-time between bit transmissions allows greater time for charge banking in passive wireless backscatter

■ Tradeoffs

- ❑ Increased complexity at the receiver
- ❑ Greater power consumption at the RF tag due to higher clock speeds necessary for spread spectrum



Near-Far Problem

- Spread spectrum works best for equal-powered RF tags
 - Far tags are weak; near ones count as many users
 - Highly problematic in backscatter due to r^4 loss
- Possible solutions
 - Interference cancellation
 - Slotted system (like IEEE 802.11b)
 - Some form of power control



Near-Far: Electronic Solution

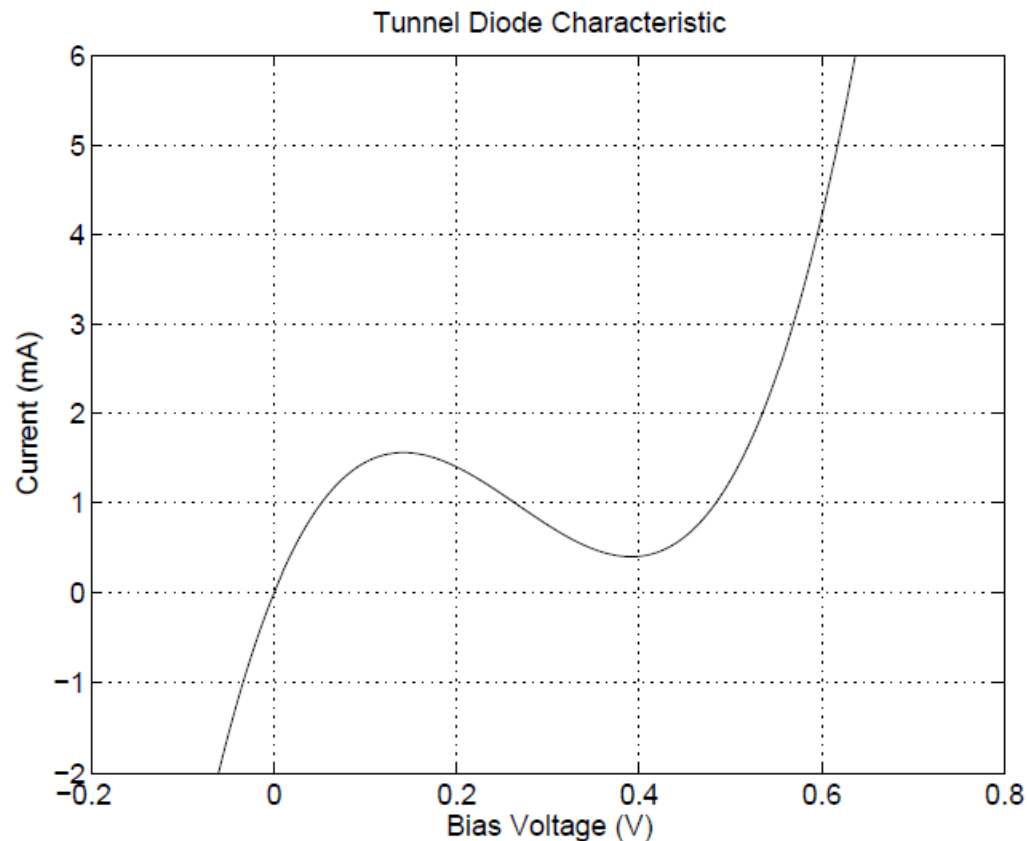

- Modulate with a tunnel diode
- Negative resistance = huge reflection
- Large incoming signal = weaker return (relative)

